

VUW120

Rectangular smoke control damper for installation in a wall.

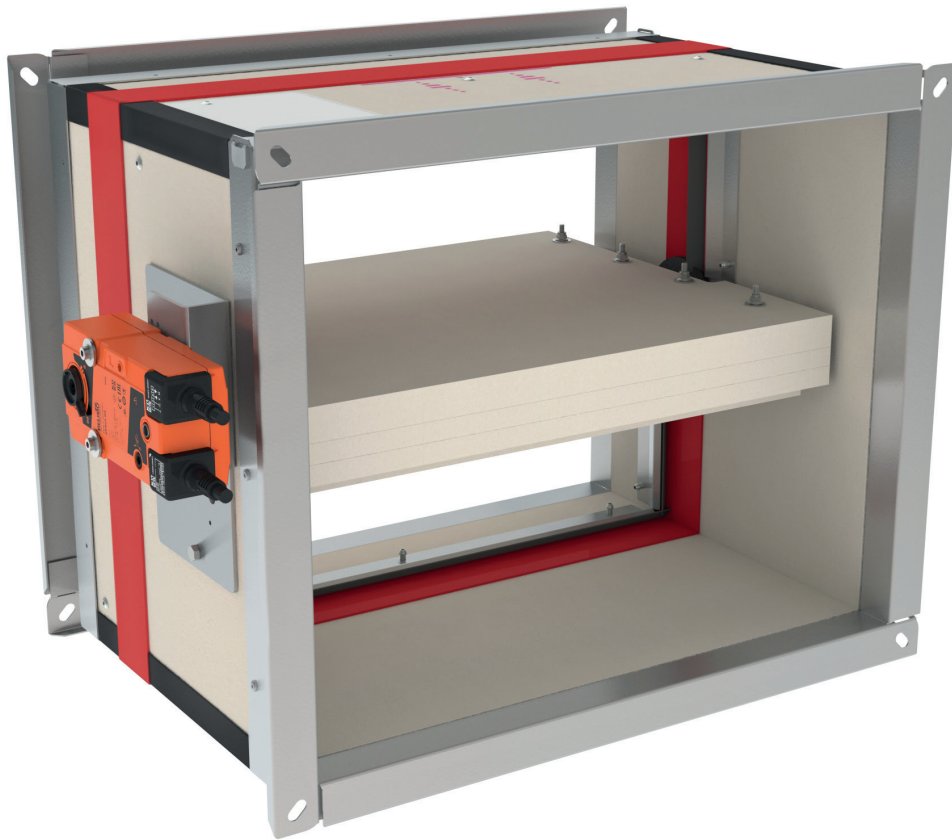

CE 1812 UK CA







Table of content

Declaration of performance	3
Product presentation VUW120	4
Range and dimensions VUW120	4
Evolution - kits	6
Options - at the time of order	7
Flange types - at the time of order	7
Storage and handling	8
Installation	8
Installation in rigid wall	9
Installation in a multi / single compartment application	10
Installation with multi compartment application on both sides	11
Operation and mechanisms	12
Electrical connection	14
Weights	15
Selection data	17
Sample order	19
Approvals and certificates	19

Explanation of the abbreviations and pictograms

Wn = nominal width	ved = vertical duct	OP = option (delivered with the product)
Hn = nominal height	hod = horizontal duct	KIT = kit (delivered separately for repair or upgrade)
Sn = free air passage	vew = vertical wall penetration	PG = connection flange to the duct
Sl = free surface	V = volt	GKB (type A) / GKF (type F): "GKB" stands for standard plasterboards (type A according to EN 520) while "GKF" plasterboards offer a higher fire resistance for a similar plate thickness (type F according to EN 520)
E = integrity	W = watt	Cal-Sil = calcium silicate
I = thermal insulation	V AC = Volt alternating current	ζ [-] = pressure loss coefficient
S = smoke leakage	V DC = Volt direct current	Q = airflow
60/120 = fire resistance time	E.TELE = power supply magnet	ΔP = static pressure drop
Pa = pascal	E.ALIM = power supply motor	v = air speed in the duct
o -> i = meets the criteria from the outside (o) to the inside (i)	Auto = automatic	Lwa = A-weighted sound power level
i <-> o = fire side not important	Tele = remote controlled	ME = motorised
AA = automatic activation	Pnom = nominal capacity	H = habitat
MA = manual activation	Pmax = maximum capacity	
multi = multi compartment	DAS MOD = modular product	

	large dimensions		optimal free air passage and minimal pressure loss
	superior air tightness (tested at 1500 Pa)		suitable for installation in rigid wall
	intermediate dimensions on request		

DECLARATION OF PERFORMANCE

CE_DoP_Rf-t_V27_EN - C-01/03/2024

1. Unique identification code of the product-type:		VUW120	
2. Intended use/s:		Smoke control damper to be used in smoke control systems, in multi-compartment applications at fire temperatures, or in single-compartment applications.	
3. Manufacturer:		Rf-Technologies NV, Lange Ambachtstraat 40, B-9860 Oosterzele	
4. System/s of AVCP:		System 1	
5. Harmonised standard / European Assessment Document; notified body / European Technical Assessment, Technical Assessment Body, notified body; certificate of constancy of performance:		EN 12101-8:2011, Efectis with identification number 1812, Efectis_1812_CPR_1596	
6. Declared performance according to EN 12101-8:2011		(fire resistance according to EN 1366-10, classification according to EN 13501-4)	
Essential characteristics			
Range	Type	Material	Sealing
300x300 mm ≤ VUW120 ≤ 1500x1000 mm	Rigid wall	Aerated concrete ≥ 100 mm	Mortar
1	Type of installation: built-in 0/180°		
		Installation	Performance Classification
		1	EI 120 (v _{ew} , t ↔ o) S1500-AA multi C10000
Harmonised standard EN 12101-8:2011			
Nominal activation conditions/sensitivity:		Pass - automatic activation	
Response delay (response time); closure time		Pass - automatic activation	
Operational reliability; cycling		BLE - 10000 cycles (C10000) (no load); BEN - 10000 cycles (C10000) (no load)	
Durability of response delay:		Pass	
Durability of operational reliability:		Pass	
High operational temperature (HOT 400/30):		NPD (no performance determined)	

The performance of the product identified above is in conformity with the set of declared performance/s. This declaration of performance is issued, in accordance with Regulation (EU) No 305/2011, under the sole responsibility of the manufacturer identified above.

Signed for and on behalf of the manufacturer by:

Duchan Laplace, R&D Manager

Oosterzele, 01/03/2024



Product presentation VUW120

The rectangular VUW120 smoke control damper is suitable for installation in a wall and offers a fire-resistance up to 120 minutes. The damper is available in large dimensions and with an optional thermal housing for the operating mechanism.

Smoke control shutters and dampers are suitable for use in ventilating protected lobbies, venting to shafts either naturally or mechanically. They open to evacuate smoke in emergency situations whilst maintaining fire resistant integrity in both directions in standby position.

- ✓ superior air tightness (tested at 1500 Pa)
- ✓ optimal free air passage and minimal pressure loss
- ✓ large dimensions



- tested according to EN 1366-10
- compliant with EN 12101-8
- suitable for installation in rigid wall
- maintenance-free
- for indoor use
- intermediate dimensions on request

1. connection flange PG30
2. casing made of refractory material
3. damper blade
4. operating mechanism in thermal housing (option)
5. sealing and blade bumper
6. intumescent strip
7. transmission
8. product identification

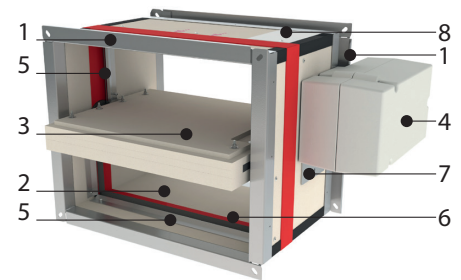

Range and dimensions VUW120

Wn/Hn in steps of 50 mm
 Exceeding blade: X = on the mechanism side, Y = on the wall side

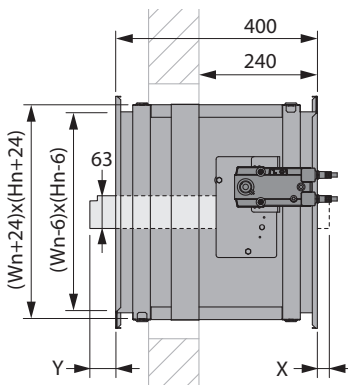

Hn (mm)	300	350	400	450	500	550	600	650	700	750	800	850	900	950	1000
x	-	-	-	-	-	1	26	51	76	101	126	151	176	201	226
y	2	27	52	77	102	127	152	177	202	227	252	277	302	327	352

IV	VA
(W x H) mm	300x300 1500x1000

VUW120+BEN

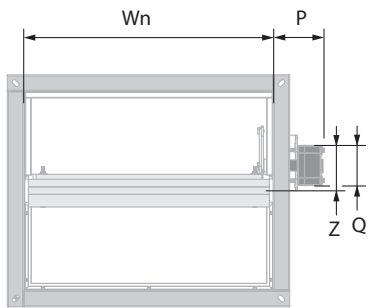

VUW120 + BLE + BOX

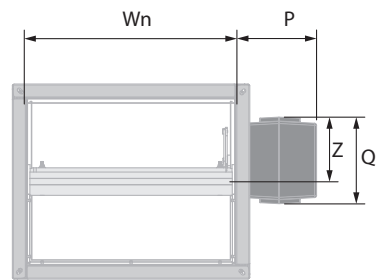

BEN

P	103
Q	90
Z	80

BLE

P	193
Q	205
Z	152

Evolution - kits



KIT BEN24

Servomotor BEN 24V



KIT BEN230

Servomotor BEN 230V



KIT BEN24-ST

Servomotor BEN 24V with plug (ST)



KIT BLE24

BLE 24V actuator for smoke control dampers



KIT BLE24-ST

BLE 24V actuator for smoke control dampers with plug (ST)



KIT BLE230



BLE 230V actuator for smoke control dampers



MECT

Testbox for mechanisms 24/48 V (magnet, motor, beginning and end of range switches)

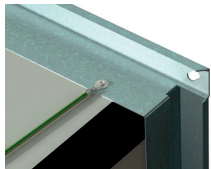
Options - at the time of order

	UL	Inspection shutter (set of 2)
	EQ	Equipotential connection
	BOX	The BOX is an optional thermal protection housing. It is specially designed to protect the motor against high temperatures.

Flange types - at the time of order

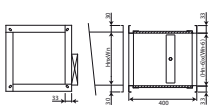
	PG30	Connection to ducts with 30 mm flanges (either by sliding profile, or with bolts, or with clamps). Elliptical holes $\varnothing 8,5 \times 16$ mm.
--	-------------	---

Storage and handling

As this product is a safety element, it should be stored and handled with care.

Avoid:

- any kind of impact or damage
- contact with water
- deformation of the casing

It is recommended:

- to unload in a dry area
- not to flip or roll the product to move it
- not to use the damper as a scaffold, working table, etc.
- not to store smaller dampers inside larger ones

Installation

General points

- The installation must comply with the installation manual and the classification report.
- The installation of the smoke control duct must comply with the classification report delivered by the manufacturer.
- Axis orientation: see the declaration of performance.
- Avoid the obstruction of adjoining smoke control ducts.
- Verify if the blade can move freely.
- Rf-t smoke dampers may be applied to smoke control ducts that have been tested according to EN 1366-8 and EN 1366-9 as appropriate, constructed from similar materials with a fire resistance, thickness and density equal or superior to these of the tested materials.
- Caution: when fitting, the product should be handled with care and remain protected from any sealing products.
- Caution: before putting the installation into operation, clean off all the dust and dirt.
- Caution: bear in mind the blade's clearance inside the smoke control duct.

Installation in rigid wall

The product was tested and approved in:

Range	Wall type	Sealing	Classification
$300 \times 300 \text{ mm} \leq \text{VUW120} \leq 1500 \times 1000 \text{ mm}$	Rigid wall	Aerated concrete $\geq 100 \text{ mm}$	Mortar
			El 120 (v _e w i ↔ o) S 1500 AA multi C10000

1

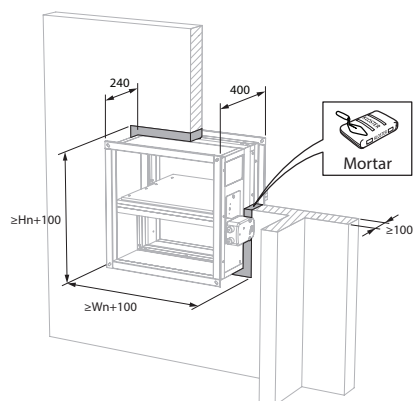

1. Make the necessary openings ($W_n + 100 \text{ mm}$) x ($H_n + 100 \text{ mm}$) in the wall.
Mount the damper in the opening.
Seal the rest of the opening with standard mortar.

2

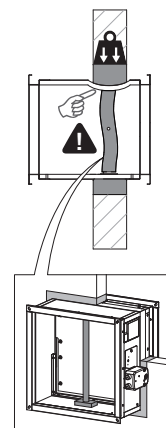

2. Support the body and block the damper blade in its closed position to prevent deformation of the body during the drying process of the sealing.

3

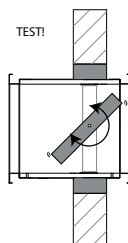

3. Check the movement of the damper blade.
Test the mechanism of the damper.

Installation in a multi / single compartment application

1

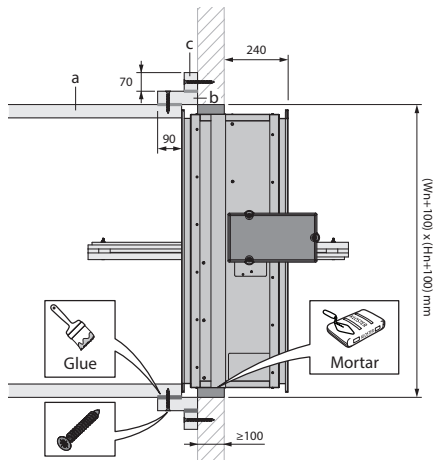

1. The multi compartment smoke extraction duct (a), made of refractory material of ≥ 50 mm thickness, is positioned against the flange of the damper. A frame (b), made of the same refractory material of ≥ 50 mm, connects the smoke extraction duct with the wall. This frame has an overlay on the duct of at least 90mm. The frame is connected to the duct using screws ($\varnothing 5 \times 90$ mm) every 150 mm and corresponding duct glue. An additional flange (c) of 70 mm height, made of the same refractory material of 50 mm or thicker, is screwed to the wall using screws suitable for that wall.

Material used:

Promatect L500 ≥ 50 mm

Duct glue: Promat K84

Screws: coarse thread $\varnothing 5 \times 90$

2

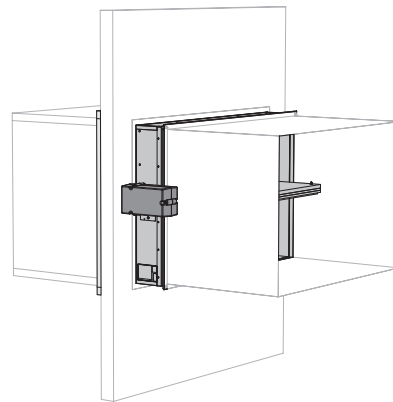

2. If required, connect single compartment smoke extraction ducts using the PG30 flange on the VUW120. The actuator could be protected by a thermal insulating box. This is not a requirement for the AA classification.

Installation with multi compartment application on both sides

1

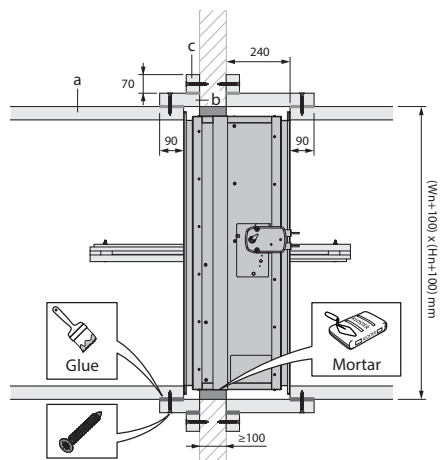

1. The multi compartment smoke extraction ducts (a), made of refractory material of ≥ 50 mm thickness, is positioned on both sides of the damper. A frame (b), made of the same refractory material of ≥ 50 mm, connects the smoke extraction ducts to the wall. These frames have an overlay on the duct of at least 90mm. The frames are connected to the duct using screws ($\varnothing 5 \times 90$ mm) every 150 mm and corresponding duct glue. Additional flanges (c) of 70mm height, made of the same refractory material of 50mm or thicker, are screwed to the wall using screws suitable for that wall.

Material used:

Promatect L500 ≥ 50 mm

Duct glue: Promat K84

Screws: coarse thread $\varnothing 5 \times 90$

2

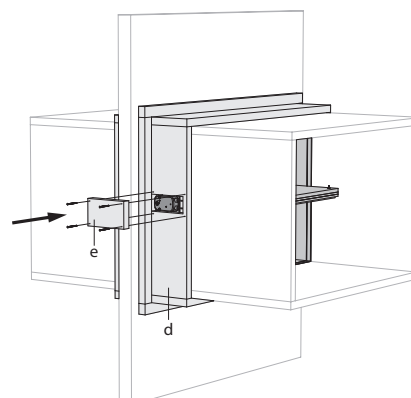

2. On the mechanism side, make an opening in frame (d) of 230 x 110 mm to access the actuator. Make a cover plate (e) of 280 x 210 mm made of the same refractory material of 50 mm or thicker. This will be used to cover the actuator, using 4 screws of $\varnothing 5 \times 90$ mm. Caulk around the electrical cables with fire resistant sealant (such as BMS f.e.).

Maintenance

- No specific maintenance required.
- Schedule at least 2 visual checks each year.
- Remove dust and all other particles before use.
- Follow local maintenance regulations (i.e. BS9999 Annex V; NF S 61-933) and EN13306.

Operation and mechanisms



BLE Actuator for remote control of smoke control dampers

The actuator BLE is specially designed to remotely control smoke control dampers. The BLE is intended for the VUW120 with BOX option and VU90-HOT only.

1. access for manual resetting
2. plug (ST)



Unlocking

- **manual unlocking:** VUW120: turn the enclosed handle clockwise / VU90-HOT: turn the enclosed handle anti-clockwise.
- **automatic unlocking:** n/a
- **remote unlocking:** power cables 1 and 2.

Caution:

⚠ Do not use a drill or powered screwdriver.

Resetting

- **manual resetting:** VUW120: turn the enclosed handle anti-clockwise / VU90-HOT: turn the enclosed handle clockwise.
- **motorised resetting:** power cables 1 and 3.

Caution:

⚠ Do not use a drill or powered screwdriver.



BEN Remotely controlled servomotor

The BEN servomotor is specifically designed for remote control of smoke control dampers.

1. access for manual operation



Options - at the time of order

BP FM Base plate for a bus communication module (Markage MB)

Unlocking

- **manual unlocking:** turn the enclosed handle anticlockwise (VRE; VU120) or clockwise (MARKAGE MB; VUW120).
- **remote unlocking:** power cables 1 and 2.

Caution:

⚠ Do not use a drill or powered screwdriver.

Resetting

- **manual resetting:** turn the enclosed handle clockwise (VRE; VU120) or anticlockwise (MARKAGE MB; VUW120).
- **motorised resetting:** power cables 1 and 3.

Caution:

⚠ Do not use a drill or powered screwdriver.

Electrical connection

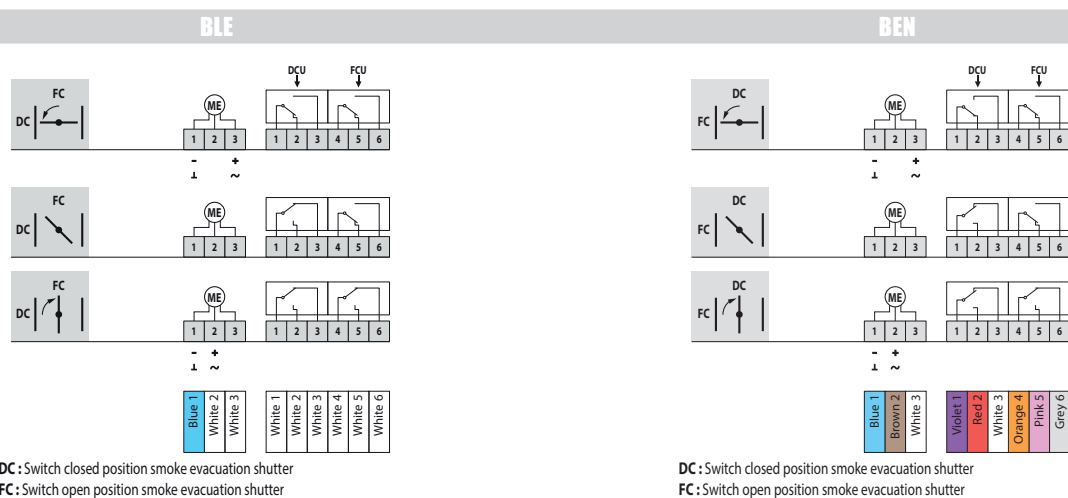

MEC	Nominal voltage motor	Nominal voltage magnet	Power consumption (stand-by)	Power consumption (operating)	Standard switches	Resetting time motor	Running time spring
BLE24	24 V AC/DC		0,5 W	7,5 W	1mA...3A, DC 5V...AC 250V	< 30 s (90°)	
BLE230	230 V AC		1 W	5 W	1mA...3A, DC 5V...AC 250V	< 30 s (90°)	
BLE24-ST	24 V AC/DC		0,5 W	7,5 W	1mA...3A, DC 5V...AC 250V	< 30 s (90°)	
BEN24	24 V AC/DC		0,1 W	3 W	1mA...3A, AC 250V	< 30 s (90°)	
BEN230	230 V AC		0,4 W	4 W	1mA...3A, AC 250V	< 30 s (90°)	
BEN24-ST	24 V AC/DC		0,1 W	3 W	1mA...3A, AC 250V	< 30 s (90°)	

MEC	Noise level motor	Noise level spring	Cable supply / control	Cable auxiliary switch	Protection class
BLE24	ca. 62 dB (A)		1 m, 3 x 0.75 mm ² (halogen-free)	1 m, 6 x 0.75 mm ² (halogen-free)	IP 54
BLE230	ca. 62 dB (A)		1 m, 3 x 0.75 mm ² (halogen-free)	1 m, 6 x 0.75 mm ² (halogen-free)	IP 54
BLE24-ST	ca. 62 dB (A)		1 m, 3 x 0.75 mm ² (halogen-free), with plug connectors	1 m, 6 x 0.75 mm ² (halogen-free), with plug connectors	IP 54
BEN24	58 dB (A)		1 m, 3 x 0.75 mm ² (halogen-free)	1 m, 6 x 0.75 mm ² (halogen-free)	IP 54
BEN230	58 dB (A)		1 m, 3 x 0.75 mm ² (halogen-free)	1 m, 6 x 0.75 mm ² (halogen-free)	IP 54
BEN24-ST	58 dB (A)		1 m, 3 x 0.75 mm ² (halogen-free), with plug connectors	1 m, 6 x 0.75 mm ² (halogen-free), with plug connectors	IP 54

Weights

VUW120 + BLE (if option BOX)

Please calculate surplus weight of 8,0 kg for the option BOX.

Hn\Wn (mm)		300	350	400	450	500	550	600	650	700	750	800	850	900	950	1000
300	kg	16,9	18,5	20,0	21,6	23,1	24,7	26,2	27,8	29,3	30,9	32,4	34,0	35,5	37,1	38,6
350	kg	18,5	20,2	21,8	23,5	25,1	26,8	28,5	30,1	31,8	33,5	35,1	36,8	38,5	40,1	41,8
400	kg	20,0	21,8	23,5	25,3	27,1	28,9	30,7	32,5	34,2	36,0	37,8	39,6	41,4	43,2	44,9
450	kg	21,5	23,4	25,3	27,2	29,1	31,0	32,9	34,8	36,7	38,6	40,5	42,4	44,3	46,2	48,1
500	kg	23,0	25,0	27,0	29,0	31,0	33,1	35,1	37,1	39,1	41,1	43,1	45,1	47,2	49,2	51,2
550	kg	24,5	26,6	28,7	30,9	33,0	35,1	37,3	39,4	41,5	43,7	45,8	47,9	50,1	52,2	54,3
600	kg	25,9	28,2	30,4	32,7	34,9	37,2	39,4	41,9	44,2	46,4	48,7	50,9	53,2	55,4	57,7
650	kg	27,4	29,8	32,2	34,5	36,9	39,3	41,9	44,2	46,6	49,0	51,3	53,7	56,1	58,4	60,8
700	kg	28,9	31,4	33,9	36,4	38,9	41,6	44,1	46,6	49,0	51,5	54,0	56,5	59,0	61,5	63,9
750	kg	30,4	33,0	35,6	38,2	41,1	43,7	46,3	48,9	51,5	54,1	56,7	59,3	61,9	64,5	67,1
800	kg	31,9	34,7	37,4	40,3	43,0	45,8	48,5	51,2	53,9	56,6	59,3	62,1	64,8	67,5	70,2
850	kg	33,4	36,3	39,3	42,2	45,0	47,8	50,7	53,5	56,3	59,2	62,0	64,8	67,7	70,5	73,3
900	kg	34,9	38,1	41,1	44,0	47,0	49,9	52,9	55,8	58,8	61,7	64,7	67,6	70,8	73,8	76,7
950	kg	36,7	39,7	42,8	45,9	48,9	52,0	55,1	58,1	61,2	64,3	67,3	70,6	73,7	76,8	79,8
1000	kg	38,2	41,4	44,5	47,7	50,9	54,1	57,3	60,4	63,6	66,8	70,2	73,4	76,6	79,8	83,0

Hn\Wn (mm)		1050	1100	1150	1200	1250	1300	1350	1400	1450	1500				
300	kg	40,2	41,7	43,3	44,8	46,4	47,9	49,5	51,0	52,6	54,1				
350	kg	43,5	45,1	46,8	48,5	50,1	51,8	53,5	55,1	56,8	58,5				
400	kg	46,7	48,5	50,3	52,1	53,8	55,6	57,4	59,2	61,0	62,8				
450	kg	50,0	51,9	53,8	55,7	57,6	59,4	61,4	63,3	65,1	67,0				
500	kg	53,2	55,2	57,2	59,3	61,3	63,3	65,3	67,3	69,3	71,3				
550	kg	56,5	58,6	60,7	62,9	65,0	67,1	69,3	71,4	73,5	75,6				
600	kg	59,9	62,2	64,4	66,7	68,9	71,2	73,4	75,7	77,9	80,2				
650	kg	63,2	65,5	67,9	70,3	72,6	75,0	77,4	79,7	82,1	84,5				
700	kg	66,4	68,9	71,4	73,9	76,3	78,8	81,3	83,8	86,3	88,8				
750	kg	69,7	72,3	74,9	77,5	80,1	82,7	85,3	87,9	90,5	93,1				
800	kg	72,9	75,6	78,4	81,1	83,8	86,5	89,2	91,9	94,6	97,4				
850	kg	76,2	79,0	81,8	84,7	87,5	90,3	93,2	96,0	98,8	101,7				
900	kg	79,7	82,6	85,6	88,5	91,4	94,4	97,4	100,3	103,2	106,2				
950	kg	82,9	86,0	89,0	92,1	95,2	98,2	101,3	104,4	107,4	110,5				
1000	kg	86,2	89,3	92,5	95,7	98,9	102,1	105,3	108,4	111,6	114,8				

VUW120 + BEN (if without option BOX)

Hn\Wn (mm)		300	350	400	450	500	550	600	650	700	750	800	850	900	950	1000
300	kg	16,3	17,9	19,4	21,0	22,5	24,1	25,6	27,2	28,7	30,3	31,8	33,4	34,9	36,5	38,0
350	kg	17,9	19,6	21,2	22,9	24,5	26,2	27,9	29,5	31,2	32,9	34,5	36,2	37,9	39,5	41,2
400	kg	19,4	21,2	22,9	24,7	26,5	28,3	30,1	31,9	33,6	35,4	37,2	39,0	40,8	42,6	44,3
450	kg	20,9	22,8	24,7	26,6	28,5	30,4	32,3	34,2	36,1	38,0	39,9	41,8	43,7	45,6	47,5
500	kg	22,4	24,4	26,4	28,4	30,4	32,5	34,5	36,5	38,5	40,5	42,5	44,5	46,6	48,6	50,6
550	kg	23,9	26,0	28,1	30,3	32,4	34,5	36,7	38,8	40,9	43,1	45,2	47,3	49,5	51,6	53,7
600	kg	25,3	27,6	29,8	32,1	34,3	36,6	38,8	41,3	43,6	45,8	48,1	50,3	52,6	54,8	57,1
650	kg	26,8	29,2	31,6	33,9	36,3	38,7	41,3	43,6	46,0	48,4	50,7	53,1	55,5	57,8	60,2
700	kg	28,3	30,8	33,3	35,8	38,3	41,0	43,5	46,0	48,4	50,9	53,4	55,9	58,4	60,9	63,3
750	kg	29,8	32,4	35,0	37,6	40,5	43,1	45,7	48,3	50,9	53,5	56,1	58,7	61,3	63,9	66,5
800	kg	31,3	34,1	36,8	39,7	42,4	45,2	47,9	50,6	53,3	56,0	58,7	61,5	64,2	66,9	69,6
850	kg	32,8	35,7	38,7	41,6	44,4	47,2	50,1	52,9	55,7	58,6	61,4	64,2	67,1	69,9	72,7
900	kg	34,3	37,5	40,5	43,4	46,4	49,3	52,3	55,2	58,2	61,1	64,1	67,0	70,2	73,2	76,1
950	kg	36,1	39,1	42,2	45,3	48,3	51,4	54,5	57,5	60,6	63,7	66,7	70,0	73,1	76,2	79,2
1000	kg	37,6	40,8	43,9	47,1	50,3	53,5	56,7	59,8	63,0	66,2	69,6	72,8	76,0	79,2	82,4

Hn\Wn (mm)		1050	1100	1150	1200	1250	1300	1350	1400	1450	1500				
300	kg	39,6	41,1	42,7	44,2	45,8	47,3	48,9	50,4	52,0	53,5				
350	kg	42,9	44,5	46,2	47,9	49,5	51,2	52,9	54,5	56,2	57,9				
400	kg	46,1	47,9	49,7	51,5	53,2	55,0	56,8	58,6	60,4	62,2				
450	kg	49,4	51,3	53,2	55,1	57,0	58,8	60,8	62,7	64,5	66,4				
500	kg	52,6	54,6	56,6	58,7	60,7	62,7	64,7	66,7	68,7	70,7				
550	kg	55,9	58,0	60,1	62,3	64,4	66,5	68,7	70,8	72,9	75,0				
600	kg	59,3	61,6	63,8	66,1	68,3	70,6	72,8	75,1	77,3	79,6				
650	kg	62,6	64,9	67,3	69,7	72,0	74,4	76,8	79,1	81,5	83,9				
700	kg	65,8	68,3	70,8	73,3	75,7	78,2	80,7	83,2	85,7	88,2				
750	kg	69,1	71,7	74,3	76,9	79,5	82,1	84,7	87,3	89,9	92,5				
800	kg	72,3	75,0	77,8	80,5	83,2	85,9	88,6	91,3	94,0	96,8				
850	kg	75,6	78,4	81,2	84,1	86,9	89,7	92,6	95,4	98,2	101,1				
900	kg	79,1	82,0	85,0	87,9	90,8	93,8	96,8	99,7	102,6	105,6				
950	kg	82,3	85,4	88,4	91,5	94,6	97,6	100,7	103,8	106,8	109,9				
1000	kg	85,6	88,7	91,9	95,1	98,3	101,5	104,7	107,8	111,0	114,2				

Selection data

$$\Delta p = 0,6 \times v^2 \times \zeta$$

Hn\Wn [mm]		300	350	400	450	500	550	600	650	700	750	800	850	900	950	1000
300	ζ [-]	1,04	0,94	0,87	0,82	0,79	0,76	0,73	0,71	0,70	0,68	0,67	0,66	0,65	0,64	0,63
350	ζ [-]	0,92	0,83	0,77	0,73	0,69	0,67	0,64	0,63	0,61	0,60	0,59	0,58	0,57	0,57	0,56
400	ζ [-]	0,82	0,75	0,69	0,65	0,62	0,60	0,58	0,56	0,55	0,54	0,53	0,52	0,51	0,51	0,50
450	ζ [-]	0,75	0,68	0,63	0,59	0,57	0,55	0,53	0,51	0,50	0,49	0,48	0,48	0,47	0,46	0,46
500	ζ [-]	0,69	0,63	0,58	0,55	0,52	0,50	0,49	0,47	0,46	0,45	0,45	0,44	0,43	0,43	0,42
550	ζ [-]	0,65	0,58	0,54	0,51	0,49	0,47	0,45	0,44	0,43	0,42	0,41	0,41	0,40	0,40	0,39
600	ζ [-]	0,60	0,55	0,51	0,48	0,46	0,44	0,42	0,41	0,40	0,39	0,39	0,38	0,38	0,37	0,37
650	ζ [-]	0,57	0,51	0,48	0,45	0,43	0,41	0,40	0,39	0,38	0,37	0,37	0,36	0,35	0,35	0,35
700	ζ [-]	0,54	0,49	0,45	0,43	0,41	0,39	0,38	0,37	0,36	0,35	0,35	0,34	0,34	0,33	0,33
750	ζ [-]	0,51	0,46	0,43	0,40	0,39	0,37	0,36	0,35	0,34	0,33	0,33	0,32	0,32	0,31	0,31
800	ζ [-]	0,49	0,44	0,41	0,39	0,37	0,35	0,34	0,33	0,33	0,32	0,31	0,31	0,30	0,30	0,30
850	ζ [-]	0,47	0,42	0,39	0,37	0,35	0,34	0,33	0,32	0,31	0,30	0,30	0,29	0,29	0,29	0,28
900	ζ [-]	0,45	0,40	0,38	0,35	0,34	0,32	0,31	0,31	0,30	0,29	0,29	0,28	0,28	0,28	0,27
950	ζ [-]	0,43	0,39	0,36	0,34	0,32	0,31	0,30	0,29	0,29	0,28	0,28	0,27	0,27	0,26	0,26
1000	ζ [-]	0,42	0,38	0,35	0,33	0,31	0,30	0,29	0,28	0,28	0,27	0,27	0,26	0,26	0,25	0,25

Hn\Wn [mm]		1050	1100	1150	1200	1250	1300	1350	1400	1450	1500				
300	ζ [-]	0,63	0,62	0,62	0,61	0,61	0,60	0,60	0,60	0,59	0,59				
350	ζ [-]	0,55	0,55	0,54	0,54	0,53	0,53	0,53	0,53	0,52	0,52				
400	ζ [-]	0,50	0,49	0,49	0,48	0,48	0,47	0,47	0,47	0,47	0,47				
450	ζ [-]	0,45	0,45	0,45	0,44	0,43	0,43	0,43	0,43	0,43	0,43				
500	ζ [-]	0,42	0,41	0,41	0,41	0,40	0,40	0,40	0,40	0,39	0,39				
550	ζ [-]	0,39	0,38	0,38	0,38	0,37	0,37	0,37	0,37	0,37	0,37				
600	ζ [-]	0,36	0,36	0,36	0,35	0,35	0,35	0,34	0,34	0,34	0,34				
650	ζ [-]	0,34	0,34	0,34	0,33	0,33	0,33	0,33	0,33	0,32	0,32				
700	ζ [-]	0,32	0,32	0,32	0,32	0,31	0,31	0,31	0,31	0,30	0,30				
750	ζ [-]	0,31	0,30	0,30	0,30	0,30	0,29	0,29	0,29	0,29	0,29				
800	ζ [-]	0,29	0,29	0,29	0,29	0,28	0,28	0,28	0,28	0,28	0,28				
850	ζ [-]	0,28	0,28	0,28	0,28	0,27	0,27	0,27	0,27	0,27	0,26				
900	ζ [-]	0,27	0,27	0,27	0,27	0,26	0,26	0,26	0,25	0,25	0,25				
950	ζ [-]	0,26	0,26	0,26	0,26	0,25	0,25	0,25	0,25	0,24	0,24				
1000	ζ [-]	0,25	0,25	0,25	0,25	0,24	0,24	0,24	0,24	0,24	0,23				

VUW120

Hn\Wn [mm]		300	350	400	450	500	550	600	650	700	750	800	850	900
300	Sn [m²]	0,0531	0,0631	0,0732	0,0832	0,0933	0,1033	0,1134	0,1234	0,1335	0,1435	0,1536	0,1636	0,1737
	Sn [%]	61,39	62,41	63,16	63,75	64,22	64,60	64,91	65,18	65,41	65,61	65,78	65,94	66,07
350	Sn [m²]	0,0663	0,0788	0,0914	0,1039	0,1165	0,1290	0,1416	0,1541	0,1667	0,1792	0,1918	0,2043	0,2169
	Sn [%]	65,52	66,60	67,41	68,04	68,53	68,94	69,28	69,57	69,81	70,02	70,21	70,37	70,52
400	Sn [m²]	0,0795	0,0945	0,1096	0,1246	0,1397	0,1547	0,1698	0,1848	0,1999	0,2149	0,2300	0,2450	0,2601
	Sn [%]	68,60	69,73	70,58	71,23	71,76	72,18	72,54	72,84	73,09	73,32	73,51	73,68	73,83
450	Sn [m²]	0,0927	0,1102	0,1278	0,1453	0,1629	0,1804	0,1980	0,2155	0,2331	0,2506	0,2682	0,2857	0,3033
	Sn [%]	70,99	72,16	73,03	73,71	74,25	74,69	75,06	75,37	75,64	75,87	76,07	76,24	76,40

Hn\Wn [mm]		300	350	400	450	500	550	600	650	700	750	800	850	900
500	Sn [m ²]	0,1059	0,1259	0,1460	0,1660	0,1861	0,2061	0,2262	0,2462	0,2663	0,2863	0,3064	0,3264	0,3465
	Sn [%]	72,89	74,09	74,99	75,69	76,24	76,70	77,07	77,39	77,67	77,90	78,11	78,29	78,45
550	Sn [m ²]	0,1191	0,1416	0,1642	0,1867	0,2093	0,2318	0,2544	0,2769	0,2995	0,3220	0,3446	0,3671	0,3897
	Sn [%]	74,44	75,67	76,59	77,30	77,87	78,33	78,72	79,04	79,32	79,56	79,77	79,96	80,12
600	Sn [m ²]	0,1323	0,1573	0,1824	0,2074	0,2325	0,2575	0,2826	0,3076	0,3327	0,3577	0,3828	0,4078	0,4329
	Sn [%]	75,74	76,99	77,92	78,64	79,22	79,69	80,08	80,41	80,70	80,94	81,16	81,35	81,51
650	Sn [m ²]	0,1455	0,1730	0,2006	0,2281	0,2557	0,2832	0,3108	0,3383	0,3659	0,3934	0,4210	0,4485	0,4761
	Sn [%]	76,83	78,10	79,04	79,78	80,36	80,84	81,24	81,57	81,86	82,11	82,33	82,52	82,69
700	Sn [m ²]	0,1587	0,1887	0,2188	0,2488	0,2789	0,3089	0,3390	0,3690	0,3991	0,4291	0,4592	0,4892	0,5193
	Sn [%]	77,76	79,05	80,01	80,75	81,34	81,82	82,23	82,57	82,86	83,11	83,33	83,52	83,69
750	Sn [m ²]	0,1719	0,2044	0,2370	0,2695	0,3021	0,3346	0,3672	0,3997	0,4323	0,4648	0,4974	0,5299	0,5625
	Sn [%]	78,57	79,87	80,84	81,59	82,19	82,67	83,08	83,42	83,72	83,97	84,19	84,39	84,56
800	Sn [m ²]	0,1851	0,2201	0,2552	0,2902	0,3253	0,3603	0,3954	0,4304	0,4655	0,5005	0,5356	0,5706	0,6057
	Sn [%]	79,28	80,59	81,56	82,32	82,93	83,42	83,83	84,17	84,47	84,73	84,95	85,15	85,32
850	Sn [m ²]	0,1983	0,2358	0,2734	0,3109	0,3485	0,3860	0,4236	0,4611	0,4987	0,5362	0,5738	0,6113	0,6489
	Sn [%]	79,90	81,22	82,21	82,97	83,58	84,07	84,49	84,84	85,13	85,39	85,62	85,82	86,00
900	Sn [m ²]	0,2115	0,2515	0,2916	0,3316	0,3717	0,4117	0,4518	0,4918	0,5319	0,5719	0,6120	0,6520	0,6921
	Sn [%]	80,45	81,78	82,78	83,54	84,16	84,66	85,07	85,42	85,72	85,98	86,21	86,41	86,59
950	Sn [m ²]	0,2247	0,2672	0,3098	0,3523	0,3949	0,4374	0,4800	0,5225	0,5651	0,6076	0,6502	0,6927	0,7353
	Sn [%]	80,95	82,29	83,28	84,06	84,67	85,18	85,60	85,95	86,25	86,51	86,74	86,94	87,12
1000	Sn [m ²]	0,2379	0,2829	0,3280	0,3730	0,4181	0,4631	0,5082	0,5532	0,5983	0,6433	0,6884	0,7334	0,7785
	Sn [%]	81,39	82,74	83,74	84,52	85,14	85,65	86,07	86,42	86,73	86,99	87,22	87,42	87,60

Hn\Wn [mm]		950	1000	1050	1100	1150	1200	1250	1300	1350	1400	1450	1500
300	Sn [m ²]	0,1837	0,1938	0,2038	0,2139	0,2239	0,2340	0,2440	0,2541	0,2641	0,2742	0,2842	0,2943
	Sn [%]	66,19	66,30	66,40	66,49	66,57	66,65	66,72	66,78	66,84	66,90	66,95	66,99
350	Sn [m ²]	0,2294	0,2420	0,2545	0,2671	0,2796	0,2922	0,3047	0,3173	0,3298	0,3424	0,3549	0,3675
	Sn [%]	70,65	70,76	70,87	70,96	71,05	71,13	71,21	71,27	71,34	71,39	71,45	71,50
400	Sn [m ²]	0,2751	0,2902	0,3052	0,3203	0,3353	0,3504	0,3654	0,3805	0,3955	0,4106	0,4256	0,4407
	Sn [%]	73,97	74,09	74,20	74,30	74,39	74,48	74,55	74,62	74,69	74,75	74,81	74,86
450	Sn [m ²]	0,3208	0,3384	0,3559	0,3735	0,3910	0,4086	0,4261	0,4437	0,4612	0,4788	0,4963	0,5139
	Sn [%]	76,54	76,67	76,78	76,89	76,98	77,07	77,15	77,22	77,29	77,35	77,41	77,47
500	Sn [m ²]	0,3665	0,3866	0,4066	0,4267	0,4467	0,4668	0,4868	0,5069	0,5269	0,5470	0,5670	0,5871
	Sn [%]	78,59	78,72	78,84	78,95	79,05	79,13	79,22	79,29	79,36	79,43	79,49	79,54
550	Sn [m ²]	0,4122	0,4348	0,4573	0,4799	0,5024	0,5250	0,5475	0,5701	0,5926	0,6152	0,6377	0,6603
	Sn [%]	80,27	80,40	80,52	80,63	80,73	80,82	80,91	80,98	81,05	81,12	81,18	81,24
600	Sn [m ²]	0,4579	0,4830	0,5080	0,5331	0,5581	0,5832	0,6082	0,6333	0,6583	0,6834	0,7084	0,7335
	Sn [%]	81,66	81,80	81,92	82,03	82,13	82,22	82,31	82,39	82,46	82,53	82,59	82,65
650	Sn [m ²]	0,5036	0,5312	0,5587	0,5863	0,6138	0,6414	0,6689	0,6965	0,7240	0,7516	0,7791	0,8067
	Sn [%]	82,84	82,98	83,10	83,21	83,32	83,41	83,50	83,58	83,65	83,72	83,78	83,84
700	Sn [m ²]	0,5493	0,5794	0,6094	0,6395	0,6695	0,6996	0,7296	0,7597	0,7897	0,8198	0,8498	0,8799
	Sn [%]	83,85	83,99	84,11	84,22	84,33	84,42	84,51	84,59	84,67	84,74	84,80	84,86
750	Sn [m ²]	0,5950	0,6276	0,6601	0,6927	0,7252	0,7578	0,7903	0,8229	0,8554	0,8880	0,9205	0,9531
	Sn [%]	84,72	84,86	84,99	85,10	85,21	85,30	85,39	85,47	85,55	85,62	85,68	85,74
800	Sn [m ²]	0,6407	0,6758	0,7108	0,7459	0,7809	0,8160	0,8510	0,8861	0,9211	0,9562	0,9912	1,0263
	Sn [%]	85,48	85,62	85,75	85,87	85,97	86,07	86,16	86,24	86,32	86,39	86,45	86,51

Hn\Wn [mm]		950	1000	1050	1100	1150	1200	1250	1300	1350	1400	1450	1500	
850	Sn [m ²]	0,6864	0,7240	0,7615	0,7991	0,8366	0,8742	0,9117	0,9493	0,9868	1,0244	1,0619	1,0995	
	Sn [%]	86,15	86,30	86,42	86,54	86,65	86,75	86,84	86,92	86,99	87,07	87,13	87,19	
900	Sn [m ²]	0,7321	0,7722	0,8122	0,8523	0,8923	0,9324	0,9724	1,0125	1,0525	1,0926	1,1326	1,1727	
	Sn [%]	86,75	86,89	87,02	87,14	87,25	87,35	87,44	87,52	87,60	87,67	87,74	87,80	
950	Sn [m ²]	0,7778	0,8204	0,8629	0,9055	0,9480	0,9906	1,0331	1,0757	1,1182	1,1608	1,2033	1,2459	
	Sn [%]	87,28	87,43	87,56	87,68	87,78	87,88	87,97	88,06	88,14	88,21	88,28	88,34	
1000	Sn [m ²]	0,8235	0,8686	0,9136	0,9587	1,0037	1,0488	1,0938	1,1389	1,1839	1,2290	1,2740	1,3191	
	Sn [%]	87,76	87,91	88,04	88,16	88,27	88,37	88,46	88,54	88,62	88,69	88,76	88,82	

Sample order

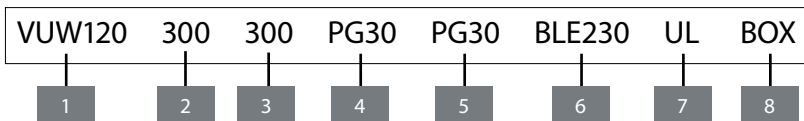

1. product
2. width
3. height
4. frame on the side of the mechanism
5. frame on the side of the wall
6. mechanism type
7. option: inspection shutter
8. option: thermal protection housing

Approvals and certificates

All our products are submitted to a number of tests by official test institutes. Reports of these tests form the basis for the approvals of the products.



Efectis_1812_CPR_1596

Efectis_2822_UKCA_CPR_0015